



## Monitoring Drills ( $\varnothing \geq 2 \text{ mm}$ )

(1 tool per motor)

### Target - setting

- Detection of tool breakage
- Improvement of workpiece quality
- Increasing of drill life
- Reduction of tool cost

### Typical use

- Machine centers
- Transfer lines
- Special purpose machines
- Milling machines

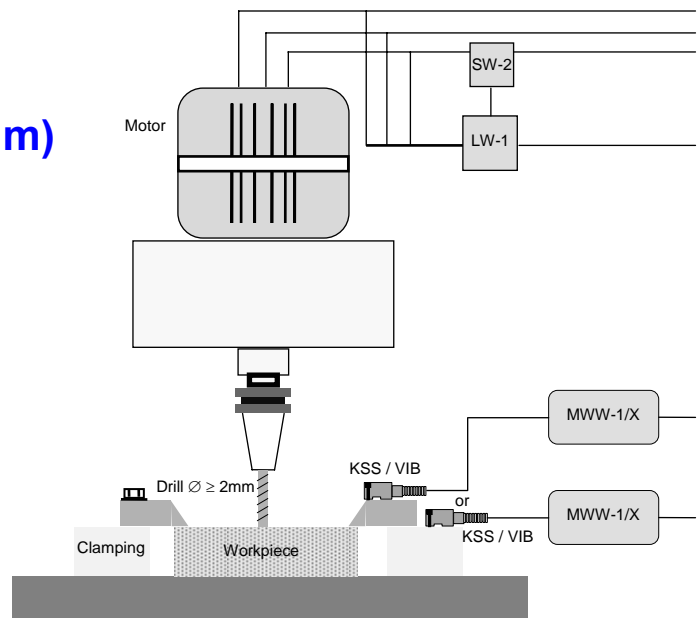

### Easy monitoring

- Drilling breakage (HSS) by active power

### Advanced monitoring

- Wear detection (HSS) by active power (trend analyzing)
- Chipped tools detection (big drilling tools with plates) by KSS / VIB

### Difficult monitoring

### Signal

