

THREAD CHASING ATTACHMENT

Attachment for multispindle automatics with mechanic motion used for threading pieces on diameters which usually can't be reached by a normal die.

This Attachment is a valid choice in alternative to thread rolling and to milling devices.

With specific variants beside external threads it's possible to obtain internal threads.

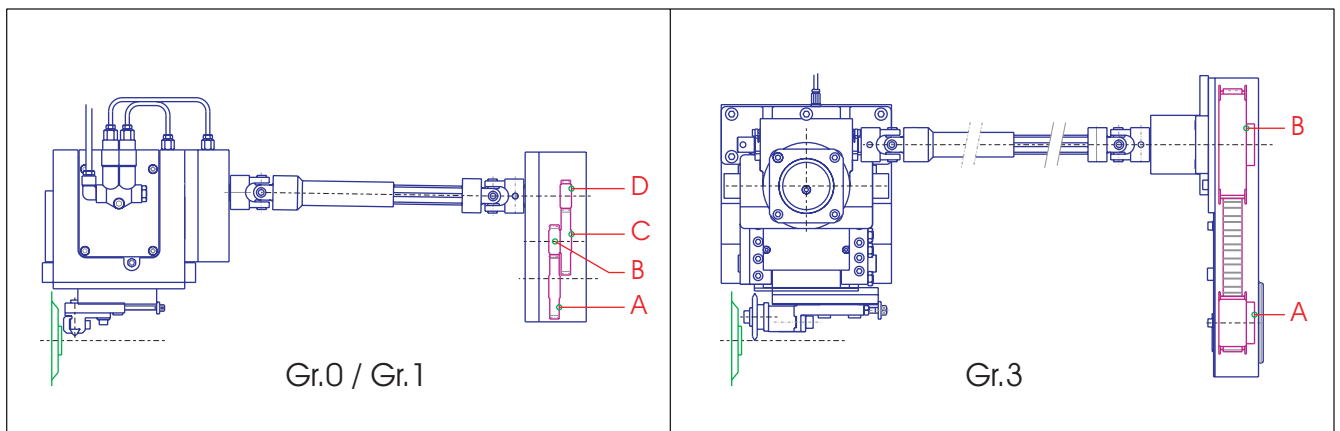
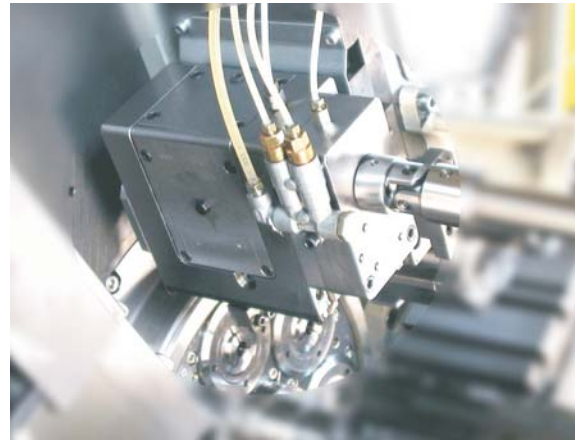

Size	Axial Stroke Ca -max-	Radial Stroke Cr -max-	Type Cam	Chasing frequency MAX	Ratio
Gr.0	16	1.5	-A-	750	1/1 - 1/16
Gr.1	22	2	-A-	700	1/1 - 1/16
Gr.3	35	2	-B-	250	1/6 - 1/28

